

DATA SHEET

E64/10/50 Planar E cores

Product specification
Supersedes data of November 1997
File under Ferrite Ceramics, MA01

1999 Dec 23

Planar E cores

E64/10/50

CORES

Effective core parameters of a set of E cores

SYMBOL	PARAMETER	VALUE	UNIT
$\Sigma(I/A)$	core factor (C1)	0.156	mm ⁻¹
V_e	effective volume	40700	mm ³
l_e	effective length	79.7	mm
A_e	effective area	511	mm ²
m	mass of core half	≈100	g

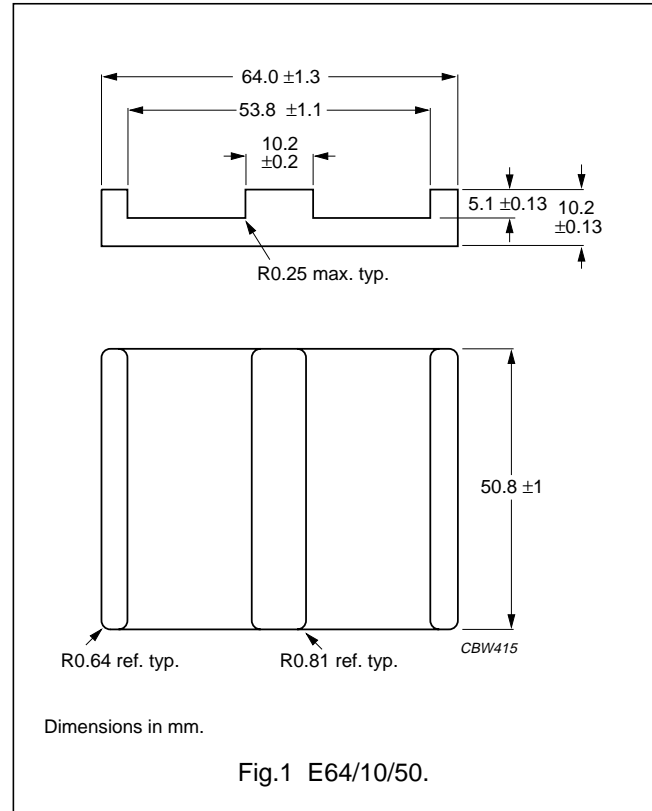

Effective core parameters of an E/PLT combination

SYMBOL	PARAMETER	VALUE	UNIT
$\Sigma(I/A)$	core factor (C1)	0.136	mm ⁻¹
V_e	effective volume	35500	mm ³
l_e	effective length	69.6	mm
A_e	effective area	511	mm ²
m	mass of plate	≈78	g

Ordering information for plates

GRADE	TYPE NUMBER
3C90	PLT64/50/5-3C90
3F3	PLT64/50/5-3F3
3F4 des	PLT64/50/5-3F4

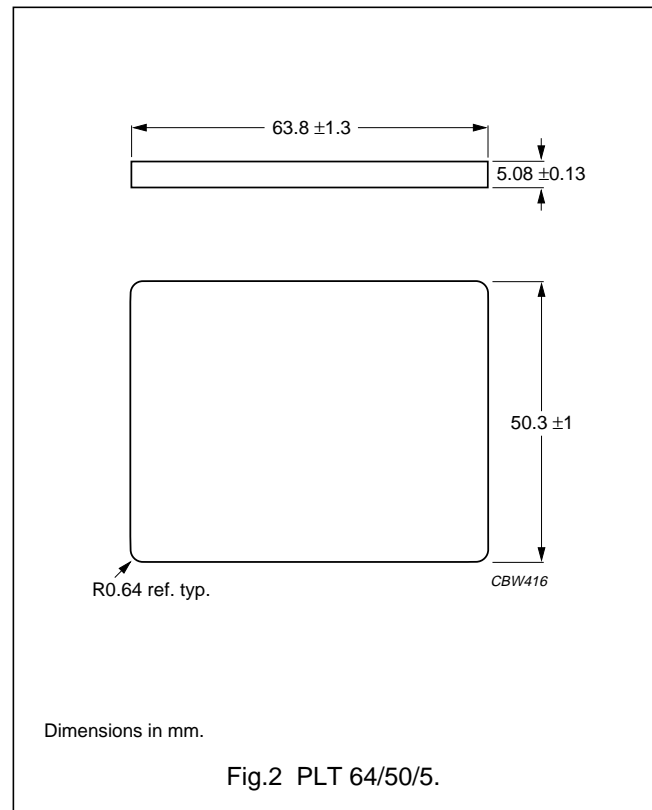

Planar E cores

E64/10/50

Core halves for use in combination with an E core

A_L measured in combination with a non-gapped core half, clamping force for A_L measurements, 100 ± 30 N, unless stated otherwise.

GRADE	A_L (nH)	μ_e	AIR GAP (μm)	TYPE NUMBER
3C90	$630 \pm 3\%^{(1)}$	≈ 78	≈ 1100	E64/10-3C90-E630-E
	$1000 \pm 3\%^{(1)}$	≈ 124	≈ 660	E64/10-3C90-E1000-E
	$1600 \pm 5\%$	≈ 199	≈ 385	E64/10-3C90-A1600-E
	$2500 \pm 10\%$	≈ 310	≈ 225	E64/10-3C90-A2500-E
	$3150 \pm 10\%$	≈ 391	≈ 170	E64/10-3C90-A3150-E
	$14640 \pm 25\%$	≈ 1820	≈ 0	E64/10/50-3C90
3F3	$630 \pm 3\%^{(1)}$	≈ 78	≈ 1100	E64/10-3F3-E630-E
	$1000 \pm 3\%^{(1)}$	≈ 124	≈ 660	E64/10-3F3-E1000-E
	$1600 \pm 5\%$	≈ 199	≈ 385	E64/10-3F3-A1600-E
	$2500 \pm 10\%$	≈ 310	≈ 225	E64/10-3F3-A2500-E
	$3150 \pm 10\%$	≈ 391	≈ 170	E64/10-3F3-A3150-E
	$13300 \pm 25\%$	≈ 1650	≈ 0	E64/10/50-3F3
3F4 des	$630 \pm 3\%^{(1)}$	≈ 78	≈ 1100	E64/10-3F4-E630-E
	$1000 \pm 3\%^{(1)}$	≈ 124	≈ 660	E64/10-3F4-E1000-E
	$1600 \pm 5\%$	≈ 199	≈ 385	E64/10-3F4-A1600-E
	$2500 \pm 10\%$	≈ 310	≈ 225	E64/10-3F4-A2500-E
	$3150 \pm 10\%$	≈ 391	≈ 170	E64/10-3F4-A3150-E
	$6960 \pm 25\%$	≈ 860	≈ 0	E64/10/50-3F4

Note

1. Measured in combination with an equa -gapped core half, clamping force for A_L measurements, 100 ± 30 N.

Core halves for use in combination with a plate (PLT)

A_L measured in combination with a plate (PLT), clamping force for A_L measurements, 100 ± 30 N.

GRADE	A_L (nH)	μ_e	AIR GAP (μm)	TYPE NUMBER
3C90	$630 \pm 3\%$	≈ 78	≈ 1100	E64/10-3C90-A-630-P
	$1000 \pm 3\%$	≈ 124	≈ 660	E64/10-3C90-A-1000-P
	$1600 \pm 5\%$	≈ 199	≈ 385	E64/10-3C90-A-1600-P
	$2500 \pm 10\%$	≈ 310	≈ 225	E64/10-3C90-A-2500-P
	$3150 \pm 10\%$	≈ 391	≈ 170	E64/10-3C90-A-3150-P
	$16540 \pm 25\%$	≈ 1790	≈ 0	E64/10/50-3C90
3F3	$630 \pm 3\%$	≈ 78	≈ 1100	E64/10-3F3-A-630-P
	$1000 \pm 3\%$	≈ 124	≈ 660	E64/10-3F3-A-1000-P
	$1600 \pm 5\%$	≈ 199	≈ 385	E64/10-3F3-A-1600-P
	$2500 \pm 10\%$	≈ 310	≈ 225	E64/10-3F3-A-2500-P
	$3150 \pm 10\%$	≈ 391	≈ 170	E64/10-3F3-A-3150-P
	$15050 \pm 25\%$	≈ 1630	≈ 0	E64/10/50-3F3

Planar E cores

E64/10/50

GRADE	A_L (nH)	μ_e	AIR GAP (μm)	TYPE NUMBER
3F4 <small>des</small>	630 \pm 3%	\approx 78	\approx 1100	E64/10-3F4-A-630-P
	1000 \pm 3%	\approx 124	\approx 660	E64/10-3F4-A-1000-P
	1600 \pm 5%	\approx 199	\approx 385	E64/10-3F4-A-1600-P
	2500 \pm 10%	\approx 310	\approx 225	E64/10-3F4-A-2500-P
	3150 \pm 10%	\approx 391	\approx 170	E64/10-3F4-A-3150-P
	7920 \pm 25%	\approx 860	\approx 0	E64/10/50-3F4

Properties under power conditions

CORE COMBINATION	B (mT) at	CORE LOSS (W) at				
	H = 250 A/m; f = 10 kHz; T = 100 °C	f = 25 kHz; \hat{B} = 200 mT; T = 100 °C	f = 100 kHz; \hat{B} = 100 mT; T = 100 °C	f = 400 kHz; \hat{B} = 50 mT; T = 100 °C	f = 1 MHz; \hat{B} = 30 mT; T = 100 °C	f = 3 MHz; \hat{B} = 10 mT; T = 100 °C
E+E64-3C90	\geq 320	\leq 4.90	\leq 5.20	–	–	–
E+PLT64-3C90	\geq 320	\leq 4.30	\leq 4.55	–	–	–
E+E64-3F3	\geq 320	–	\leq 4.50	\leq 7.80	–	–
E+PLT64-3F3	\geq 320	–	\leq 3.95	\leq 6.80	–	–
E+E64-3F4	\geq 250	–	–	–	\leq 12.0	\leq 15.0
E+PLT64-3F4	\geq 250	–	–	–	\leq 10.5	\leq 13.0